

**3-phase AC
technology (48 V)
for high productivity**

**Ergonomically designed
operator workplace**

**Multi-pallet
transportation for
up to 3 pallets**

High travel speeds



ESE 420/430/530

Electric sideways seat pallet truck (48 V)

The Jungheinrich electric pallet trucks with sideways seat, ESE 420/430/530, are ideally suited for multi-pallet transportation over long distances. Equipped with 48 V motors in 3-phase AC technology, they ensure a smooth start, powerful acceleration and high top speeds. In short: they create optimum conditions for high throughput. The ESE 530 with two drive motors underlines this performance. The series 4 and 5 ESE have battery capacities from 500 to 1000 Ah, giving every customer the ability to tailor his/her applica-

tion to the correct battery size. The advantages of a thoroughly robust construction are an additional bonus. Chassis and load sections are designed for capacities up to 3000 kg. This high performance can be achieved with ease and in total safety: travel speed, brake and deadman switch are controlled by the use of easily accessible pedals. All other functions are controlled from the comfortable operating unit. The horizontally adjustable operating console is adaptable to the requirements of any operator.

Other available equipment:

- Suspended operator cab (only for ESE 530).
- Individually adjustable travel parameters.
- Clear operator display.
- Comfort seat (supplied as standard for ESE 530, optionally available for ESE 420/430).
- Entry door with door opener on the inside and various storage facilities (supplied as standard for ESE 530 m optionally available for ESE 420/430).

**JUNGHEINRICH**

ESE 420/430/530

ESE 420/430

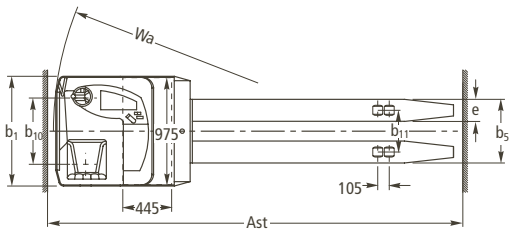
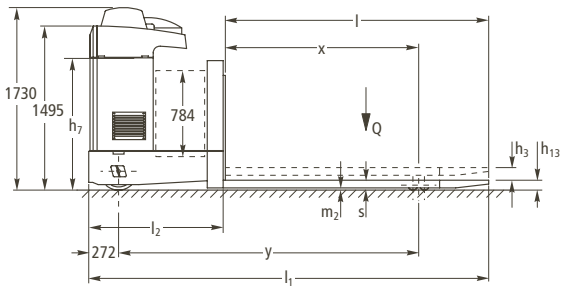

ESE 530

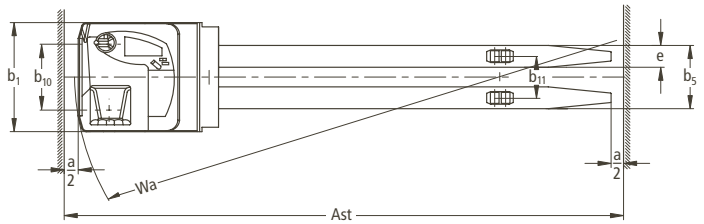
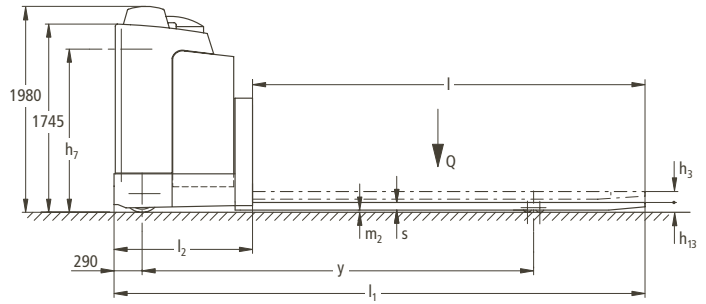

Technical Data in line with VDI 2198 as at: 06/2006

Identification	1.1	Manufacturer (abbreviation)	Jungheinrich	Jungheinrich	Jungheinrich	1.1
	1.2	Manufacturer's type designation	ESE 420 (48 V)	ESE 430 (48 V)	ESE 530 (48 V)	1.2
	1.3	Drive (electric – battery or mains, diesel, petrol, fuel gas, manual)	electric	electric	electric	1.3
	1.4	Type of operation (hand, pedestrian, standing, seated, order picker)	seat	seat	seat	1.4
	1.5	Load capacity/rated load Q (t)	2	3	3	1.5
Weights	1.8	Load distance, centre of drive axle to fork x (mm)	1840	1490	2214	1.8
	1.9	Wheelbase y (mm)	2793/2704 ²⁾	2443/2354 ²⁾	2677/2570 ²⁾	1.9
Wheels, Chassis	2.1	Service weight incl. battery (see line 6.5) kg	2790	2870	3650	2.1
	2.2	Axle loading, laden front/rear kg	2630/2160	2890/2980	3550/3100	2.2
	2.3	Axle loading, unladen front/rear kg	2210/580	2260/610	2900/750	2.3
	3.1	Tyres (solid rubber, superelastic, pneumatic, polyurethane)	Vulkollan®	Vulkollan®	Vulkollan®	3.1
	3.2	Tyre size, front	343 x 140	343 x 140	343 x 140	3.2
	3.3	Tyre size, rear	85 x 80	90 x 92	90 x 92	3.3
	3.4	Additional wheels (dimensions)	200 x 100	200 x 100	–	3.4
Basic Dimensions	3.5	Wheels, number front/rear (x = driven wheels)	2-1x/4	2-1x/4	2x/4	3.5
	3.6	Track width, front b ₁₀ (mm)	604	604	604	3.6
	3.7	Track width, rear b ₁₁ (mm)	380	380	380	3.7
	4.4	Lift height h ₃ (mm)	115	115	115	4.4
	4.8	Seat height/standing height h ₇ (mm)	1200	1200	1450	4.8
	4.15	Lowered height h ₁₃ (mm)	90	90	95	4.15
	4.19	Overall length l ₁ (mm)	3625	3625	4860	4.19
	4.20	Length to face of forks l ₂ (mm)	1225	1225	1280	4.20
	4.21	Overall width b ₁ /b ₂ (mm)	1000	1000	1000	4.21
	4.22	Fork dimensions s/e/l (mm)	60 x 180 x 2400	70 x 200 x 2400	70 x 200 x 3600	4.22
	4.25	Width over forks b ₅ (mm)	520/560	580	580	4.25
	4.32	Ground clearance, centre of wheelbase m ₂ (mm)	30	30	20	4.32
	Performance Data	4.34	Aisle width for pallets 800 x 1200 lengthways Ast (mm)	4060	3955	5533
4.35		Turning radius Wa (mm)	3115/3021 ²⁾	2760/2671 ²⁾	3860/3871 ²⁾	4.35
5.1		Travel speed, laden/unladen km/h	13/15	13/15	18.8/19.0	5.1
5.2		Lift speed, laden/unladen m/s	0.056/0.06	0.056/0.06	0.056/0.06	5.2
5.3		Lowering speed, laden/unladen m/s	0.052/0.05	0.052/0.05	0.052/0.05	5.3
E-Motor	5.7	Gradient performance, laden/unladen %	6/15	6/15	6/15	5.7
	5.10	Service brake	mechanic/hydraulic	mechanic/hydraulic	mechanic/hydraulic	5.10
	6.1	Drive motor rating S ₂ 60 min. kW	6.9	6.9	6.0 / 6.0 ¹⁾	6.1
	6.2	Lift motor rating at S ₃ 15 % kW	3	3	3	6.2
	6.3	Battery acc. to DIN 43531 / 35/36 A, B, C, no	EN 60254-2 (circuit "A")	EN 60254-2 (circuit "A")	EN 60254-2 (circuit "A")	6.3
Others	6.4	Battery voltage, nominal capacity K ₅ V/Ah	48/560	48/560	48/1000	6.4
	6.5	Battery weight kg	945	945	1440	6.5
	8.1	Type of drive control	MOSFET control AC	MOSFET control AC	MOSFET control AC	8.1

1) performance 1st motor / performance 2nd motor
2) lowered/raised

Make use of the advantages

Innovative 3-phase AC technology

Jungheinrich motors in 3-phase AC technology are highly efficient and reduce operating costs over the whole life of the truck. These are the advantages:

- Highly efficient use of power.
- Smooth start and powerful acceleration.
- Quick direction change without customary delay.
- No carbon brushes – the drive motor is maintenance-free.
- 2-year warranty on drive motor.

Comfortable operation and control

- Ease of operation via fully electric steering. The exact position of the drive wheels can be seen at any time by means of innovative sensors.
- The driver operates lifting, lowering and horn functions via the multi-function lever. The travel direction is changed via integral toggle switch.
- Easily readable display (e.g. battery discharge monitor).
- Easy access to handbrake and emergency stop.



Operator cab

Ergonomically designed operator workplace

- Horizontally adjustable control panel.
- Various storage facilities (parts tray, drinks holder).
- Comfortable door with door opener on the inside and filing tray (optional for ESE 420/430).
- Comfortable sitting position on comfort seat with weight adjustment (optional for ESE 420/430) and ergonomic armrest – ideal for long, intensive driving.
- Suspended operator cab (ESE 530).

Clear operator display

High-quality control instruments for display of the most important operating data:

- Travel direction.
- Battery discharge indicator with residual energy display.



Operator door for added safety

- Operating hours.
- Steering position display (only ESE 420/ ESE 430).
- Selected drive programs (only ESE 420/ ESE 430).

Robust construction for intensive applications

- Chassis made of high-quality 20 mm steel for continuous application with full rated load.
- Robust, torsion-resistant forks with particularly strong tie rods made of special steel. Available in many lengths and widths.

Reduced maintenance

Service-friendly components ensure long-term reduction in operating costs:

- Maintenance-free 3-phase AC drive motor without carbon brushes.
- Quick access to all components through hinged access.



Easily accessible aggregates through foldable doors

Jungheinrich Hellas EPE

10, Filippoupoleos str.
Thesi Loutro
136 71 Acharnes
Greece
Tel. 0030 210 2447800
Fax 0030 210 2447799

info@jungheinrich.gr
www.jungheinrich.gr

Jungheinrich AG
ISO 9001, ISO 14001
Certification of Quality and
Environment Management.



Jungheinrich trucks
conform to the European
Safety Requirements.



JUNGHEINRICH
Η επιλογή που αξίζει