

**Low noise levels:  
only 71 dB(A) in the cab**

**Comfortable workplace**

**Tilting cab**

**Most up-to-date  
6-cylinder Turbo-Diesel**

**Maintenance-free  
laminated brakes**



## **DFG 660/670/680/690/S80**

### **Diesel forklift truck with hydrodynamic drive (6000, 7000, 8000, 9000 kg)**

Jungheinrich Diesel stackers with hydrodynamic drive (converter drive) and turbo diesel industrial engines provide high throughput efficiency and availability also in 3-shift operation.

The industrial engines, specially designed for application in fork lift trucks, provide maximum reliability and long service life even in the hardest applications. High torque at low rpm is also a contributory factor. It facilitates

high efficiency whilst at the same time incorporating low fuel consumption and low noise development.

Another virtue of industrial engines is the low exhaust emission that already conforms to future EU regulations. A number of environment-protecting soot filter systems (optional) are also available that ensure requirement-appropriate adjustment to any application.

The 6 to 9 t stackers are also ready for any application with regard to travel and operating comfort. The ergonomic design of the entire workplace offers both safety and comfort and protects the operator's health. Thus the high efficiency stackers provide the best conditions for relaxed, concentrated, highly efficient operators.

**JUNGHEINRICH**

# DFG 660/670/680/690/S80

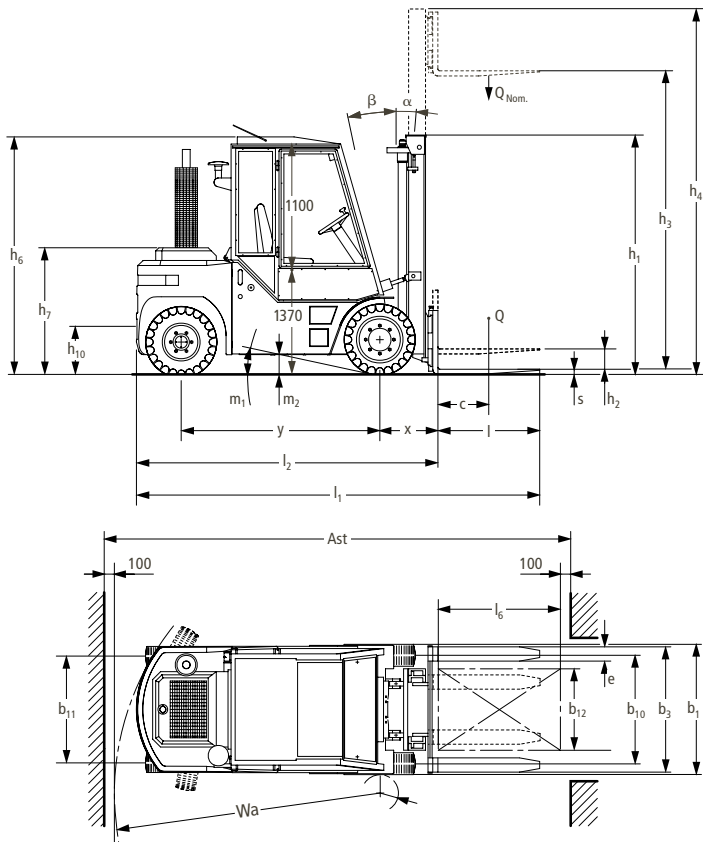

## Capacity

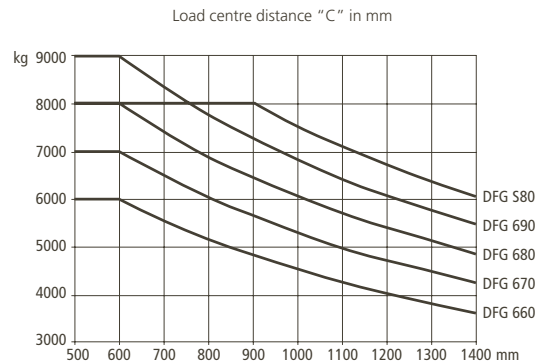

Mast table DFG 660-580							Capacity table (kg)					
Mast type	Lift height h <sub>3</sub> (mm)	Free lift h <sub>2</sub> (mm)	Closed height h <sub>1</sub> (mm)	Extended height h <sub>4</sub> (mm)		Forward/backward tilt (degree)	c = 600 mm					
			<b>DFG 660</b>	<b>DFG 660</b>	<b>DFG 660</b>		<b>DFG 660</b>					
ZT	3300	0	2500	4400	4400	6/9	6000					
	3600	0	2650	4700	4700	6/9	6000					
	4000	0	2850	5100	5100	6/9	6000					
	4500	0	3100	5600	5600	6/9	5560					
	5000	0	3350	6100	6100	6/9	5380					
	5500	0	3600	6600	6600	6/9	5200					
ZZ	3300	1650	2515	4400	4400	6/9	6000					
	3600	1800	2665	4700	4700	6/9	6000					
	4000	2000	2865	5100	5100	6/9	6000					
	4500	2250	3115	5600	5600	6/9	5560					
	5000	2500	3365	6100	6100	6/9	5380					
	5500	2500	3365	6100	6100	6/9	5380					
DZ	4000	1410	2293	5030	5030	6/5	5710					
	4500	1570	2460	5530	5530	6/5	5300					
	5000	1730	2626	6030	6030	6/5	5130					
	5500	1890	2793	6530	6530	6/5	4950					
	6000	2050	3027	7030	7030	6/5	4780					
	6600	2090	3360	7870	7870	6/5	4480					
			<b>DFG 670-680</b>	<b>DFG 690-580</b>	<b>DFG 670-680</b>	<b>DFG 690-580</b>	<b>DFG 670-680</b>	<b>DFG 690-580</b>	c = 600 mm			c = 900 mm
ZT	3300	0	2550	2860	4360	4360	6/9	7000	8000	9000	8000	
	3600	0	2700	3010	4660	4660	6/9	7000	8000	9000	8000	
	4000	0	2900	3210	5060	5060	6/9	7000	8000	9000	8000	
	4500	0	3150	3460	5560	5560	6/9	7000	8000	9000	8000	
	5000	0	3400	3710	6060	6060	6/9	7000	8000	9000	8000	
	5500	0	3650	3960	6560	6560	6/9	6500	7500	8250	7250	
ZZ	3300	1650	2725	2875	4375	4525	6/9	7000	8000	9000	8000	
	3600	1800	2875	3025	4675	4825	6/9	7000	8000	9000	8000	
	4000	2000	3075	3225	5075	5225	6/9	7000	8000	9000	8000	
	4500	2250	3325	3475	5575	5725	6/9	7000	8000	9000	8000	
	5000	2500	3575	3725	6075	6225	6/9	7000	8000	9000	8000	
	5500	2500	3575	3725	6075	6225	6/9	7000	8000	9000	8000	
DZ	4000	1333	2418	2568	5085	5235	6/5	6720	7720	8720	7720	
	4500	1500	2585	2735	5585	5735	6/5	6720	7720	8720	7720	
	5000	1667	2752	2902	6085	6235	6/5	6720	7720	8720	7720	
	5500	1833	2918	3068	6585	6735	6/5	6220	7220	7970	6970	
	6000	2000	3085	3235	7085	7235	6/5	6220	7220	7970	6970	
	6600	2167	3252	3402	7585	7735	2/3   6/5	6090	7090	7820	6820	

# Technical Data in line with VDI 2198 as at: 10/2006

Identification	1.1	Manufacturer (abbreviation)	Jungheinrich	Jungheinrich	Jungheinrich	Jungheinrich	Jungheinrich	1.1
	1.2	Manufacturer's type designation	<b>DFG 660</b>	<b>DFG 670</b>	<b>DFG 680</b>	<b>DFG 690</b>	<b>DFG 580</b>	1.2
	1.3	Drive (electric, diesel, petrol, LPG, mains current, manual)	diesel	diesel	diesel	diesel	diesel	1.3
	1.4	Type of operation (hand, pedestrian, standing, seated, order picker)	seated	seated	seated	seated	seated	1.4
	1.5	Load capacity/rated load Q (t)	6	7	8	9	8	1.5
	1.6	Load centre distance c (mm)	600	600	600	600	900	1.6
	1.8	Load distance, centre of drive axle to fork x (mm)	626	649	649	654	664	1.8
	1.9	Wheelbase y (mm)	2225	2475	2675	2675	2675	1.9
	Weights	2.1	Service weight kg	10060	10590	11000	12200	13600
2.2		Axle loading, laden front/rear kg	13850/2210	15575/2015	17187/1813	19025/2175	18900/2625	2.2
2.3		Axle loading, unladen front/rear kg	4540/5520	5110/5480	5520/5480	5610/6620	6300/7300	2.3
Wheels, Chassis	3.1	Tyres (solid rubber, superelastic, pneumatic, polyurethane)	SE (L)	SE (L)	SE (L)	SE (L)	SE (L)	3.1
	3.2	Tyre size, front	355/65-15	355/65-15	8.25-15	8.25-15	300-15	3.2
	3.3	Tyre size, rear	8.25-15	8.25-15	8.25-15	8.25-15	300-15	3.3
	3.5	Wheels, number front/rear (x = driven wheels)	2 (x)/2	2 (x)/2	4 (x)/2	4 (x)/2	4 (x)/2	3.5
	3.6	Track width, front b <sub>10</sub> (mm)	1285	1465	1510	1510	1510	3.6
	3.7	Track width, rear b <sub>11</sub> (mm)	1296	1296	1296	1296	1460	3.7
	Basic Dimensions	4.1	Mast/fork carriage tilt forward/backward $\alpha/\beta$ (°)	6/9	6/9	6/9	6/9	6/9
4.2		Lowered mast height h <sub>1</sub> (mm)	2500	2560	2860	3010	3010	4.2
4.4		Lift height h <sub>3</sub> (mm)	3300	3300	3300	3300	3300	4.4
4.5		Extended mast height h <sub>4</sub> (mm)	4270	4360	4360	4360	4360	4.5
4.7		Overhead load guard (cab) height h <sub>6</sub> (mm)	2510	2510	2510	2510	2510	4.7
4.8		Seat height/standing height h <sub>7</sub> (mm)	1440	1440	1440	1440	1440	4.8
4.12		Coupling height h <sub>10</sub> (mm)	500/750	500/750	500/750	500/750	500/750	4.12
4.19		Overall length l <sub>1</sub> (mm)	4676	4884	5034	5134	5634	4.19
4.20		Length to face of forks l <sub>2</sub> (mm)	3476	3684	3834	3934	3834	4.20
4.21		Overall width b <sub>1</sub> /b <sub>2</sub> (mm)	1640	1820	2020	2020	2150	4.21
4.22		Fork dimensions s/e/l (mm)	50x150x1200	60x150x1200	60x150x1200	65x150x1200	70x150x1800	4.22
4.23		Fork carriage ISO 2328, class/type A, B	4 A	4 A	4 A	4 A	4 A	4.23
4.24		Fork carriage width b <sub>3</sub> (mm)	1500	1800	2000	2000	2100	4.24
4.31		Ground clearance, laden, under mast m <sub>1</sub> (mm)	250	250	250	250	250	4.31
4.32		Ground clearance, centre of wheelbase m <sub>2</sub> (mm)	250	250	250	250	250	4.32
4.33		Aisle width for pallets 1000x1200 crossways Ast (mm)	5006	5449	5599	5699	5599	4.33
4.34	Aisle width for pallets 800x1200 lengthways Ast (mm)	5206	5649	5799	5904	5799	4.34	
4.35	Turning radius Wa (mm)	3180	3600	3750	3850	3750	4.35	
4.36	Smallest pivot point distance b <sub>13</sub> (mm)	1120	1500	1680	1680	1680	4.36	
Performance Data	5.1	Travel speed, laden/unladen km/h	23/25	23/25	23/25	23/25	23/25	5.1
	5.2	Lift speed, laden/unladen m/s	0.50/0.48	0.40/0.48	0.40/0.48	0.40/0.48	0.40/0.48	5.2
	5.3	Lowering speed, laden/unladen m/s	0.60/0.32	0.60/0.32	0.60/0.32	0.60/0.32	0.60/0.32	5.3
	5.5	Drawbar pull, laden/unladen N	45700/31500	44500/32700	44300/32700	43900/33000	43900/33000	5.5
	5.7	Gradient performance, laden/unladen %	28/30	26/30	24/28	22/26	22/26	5.7
	5.9	Acceleration time, laden/unladen s	5/6	5/6	6.8/5.8	6.8/5.8	6.8/5.8	5.9
5.10	Service brake	hydraulic	hydraulic	hydraulic	hydraulic	hydraulic	5.10	
V-Motor	7.1	Engine manufacturer/type	Detroit/HR 694 HT3	Detroit/HR 694 HT3	Detroit/D 706IE2	Detroit/D 706IE2	Detroit/D 706IE2	7.1
	7.2	Engine power acc. to ISO 1585 kW	82	82	82	82	82	7.2
	7.3	Rated speed 1/min	2450	2450	2450	2450	2450	7.3
	7.4	No. of cylinders/cubic capacity anz/cm <sup>3</sup>	6/4164	6/4164	6/4164	6/4164	6/4164	7.4
	7.5	Fuel consumption acc. to VDI cycle l/h, kg/h	5.9	5.9	5.6	5.6	5.6	7.5
Others	8.1	Type of drive control	hydrodynamic	hydrodynamic	hydrodynamic	hydrodynamic	hydrodynamic	8.1
	8.2	Operating pressure for attachments bar	150	150	150	150	150	8.2
	8.3	Oil volume for attachments l/min	80	80	80	80	80	8.3
	8.4	Sound level at driver's ear according to EN 12053 dB(A)	71	71	71	71	71	8.4

# Make use of the advantages

## Operator compartment

Comfort and efficiency-promoted through excellent ergonomics:

- Simple and safe mounting and dismounting through low entry height.
- Operator workplace module completely sealed off from engine. Damped against sound and vibration through hydraulic buffers.
- Steplessly adjustable, mechanically cushioned comfort seat (air cushioning optional).
- Steplessly adjustable steering column.
- Hydraulic levers fixed to the operator seat that follow every seat adjustment automatically.
- Travel direction switch on steering column (fixed on acceleration pedal or to hydraulic lever on control valve is available as an option).
- Large, comfortable foot room with pedals arranged as in a motor car.
- Excellent visibility through mast due to cylinders arranged behind mast profiles.
- Clear instrument panel with analogue display and extensive warning and control lights.
- Comfortable working environment in any weather through comfort cabs (optional) in various designs.

## Engines

Propulsive power is provided by turbo-diesel industrial engines that were specially designed for fork lift trucks:

- DFG 660–670: 4.2 l/6 cylinder turbo-diesel engine with indirect injection and 82 kW power output at 2450 rpm. Maximum torque (370 Nm) at 1800 rpm.
- DFG 680–690 and S80: 4.2 l/6 cylinder turbo-diesel engine (Detroit Diesel D 706 IE2) with direct injection and 82 kW power output at 2450 rpm. Maximum torque (440 Nm) at 1400 rpm.



Excellent visibility through the mast

- Efficient engines with low rpm level and high torque.
- Clean exhaust emissions clearly below valid emission limit values according to ISO 8178.
- 400 operating hours service intervals.
- Different types of soot filter systems (optional).
- 120 l fuel tank integrated in chassis.

## Drive

The hydrodynamic drive with automatic 2-speed power shift gear ensures economic, requirement-oriented power transmission. Other advantages:

- Sensitive and jerk-free power transmission.
- Automatic gear shift and electronically controlled shift lock at a travel speed of more than 4 km/h.
- Combined crawl speed/brake pedal for sensitive travelling at full lift performance.

## Electrics

12 Volt battery with 135 Ah/115 A alternator.

## Steering

Maximum steering comfort and high safety through:

- Hydrostatic steering for effortless, precise steering.
- Steering axle with integrated steering cylinder.

## Brake

Two independent brake systems act upon the front wheels:

- Foot brake: servo-hydraulic, maintenance-free laminated brake in oil bath with brake power booster.
- Parking brake: electro-hydraulic disc brake activated via manual switch and fitted with operation warning light.

## Hydraulics

The high efficiency filter system ensures clean hydraulic oil and contributes towards long service life of all components.

- Suction filter and extra fine filter in return pipe.
- 120 l hydraulic tank integrated in chassis.
- Ventilation of hydraulic tank via filter.
- Pressure relief valves protect against excess pressure and overloading (load sensing technology).

## Mast

All mast components are designed for optimised visibility conditions, maximum stability and long service life.

- Slender mast profiles and lift cylinders positioned at the rear for wide visual range window.
- Clear view fork carriage for optimised visibility.
- Fork carriage according to FEM/ISO-2328-4A.

## Options

Various options and attachments are available for adjustments to different application requirements or customer requests.

## Jungheinrich Hellas EPE

10, Filippoupoleos str.  
Thesi Loutro  
136 71 Acharnes  
Greece  
Tel. 0030 210 2447800  
Fax 0030 210 2447799

info@jungheinrich.gr  
www.jungheinrich.gr

Jungheinrich AG  
ISO 9001, ISO 14001  
Certification of Quality and  
Environment Management.



Jungheinrich trucks  
conform to the European  
Safety Requirements.



**JUNGHEINRICH**  
Η επιλογή που αξίζει