

**Compact forklift with AC technology  
and rear-wheel drive**

**Maximum performance  
with low energy consumption**

**990 mm wide for block stacking**

**Spacious operator's cab**

**SOLO- or MULTI-PILOT control  
lever (optional)**

**Processor-controlled  
update-capable AC electronics**



## **EFG 110–115**

### **Electric three-wheel forklift truck (1000, 1250, 1500 kg)**

Rear-wheel drive, compact design, high performance, an ergonomically designed operator compartment. These are the strengths of the Jungheinrich electric forklift trucks EFG 110k/110–115. The advantages: high manoeuvrability, optimum performance in confined spaces and a high level of operator comfort.

Low step for safe and comfortable entrance to the cushion mounted cab. The adjustable steering column and the three-

way adjustable comfort seat offer individual adaptation to all operators. The comfort high roof is 2090 mm high and offers superior headroom ("container roof" with a height of 1970 mm is available as an option). Excellent all round visibility enhances safety; the ergonomically positioned hydraulic levers to the right of the driver's seat in SOLO-PILOT control (separate levers) or MULTI-PILOT control (all functions in one lever) for optimum handling. With a clear text indicator the

comfort display highlights all important vehicle data, for example operating hours, battery charge and brake system. The system also stores all relevant service data. Low steering and lever operating forces and a familiar automotive pedal layout ensures safe operation. The encapsulated motor with AC technology enables smooth acceleration, suitable for both indoor and outdoor operation.

# EFG 110k/110-115

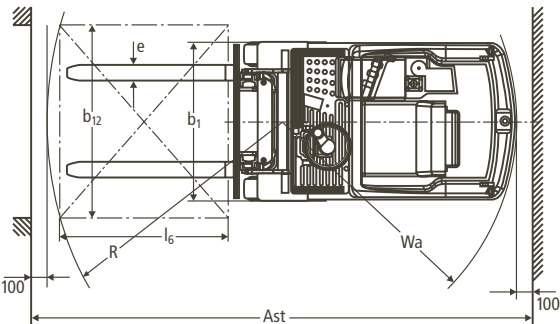
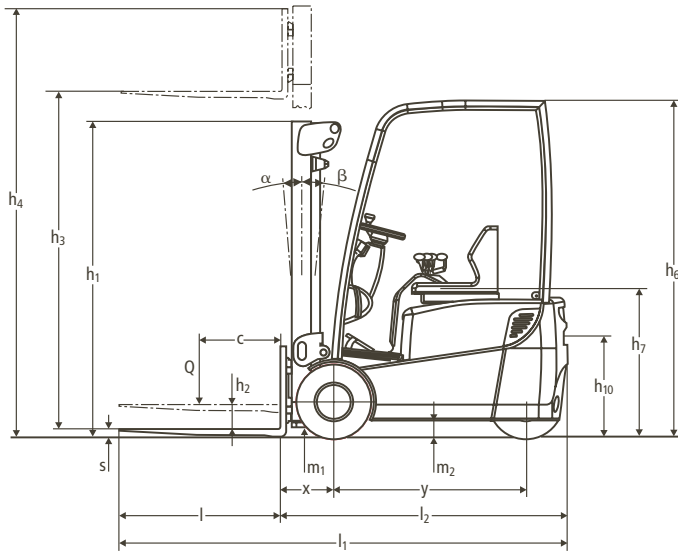

## Capacity

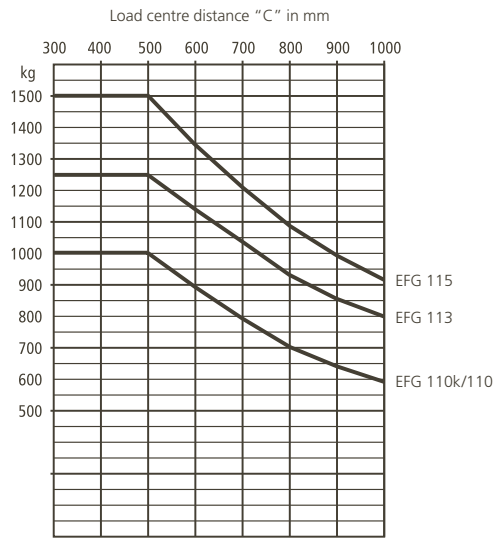

Designation	Mast table EFG 110k/110-115					Capacity table (kg) c = 500 mm				Truck	
	Lift height	Free lift	Closed mast height	Extended mast height	Forward/backward tilt	without sideshift, single solid tyres				Width	Track
						EFG 110k	EFG 110	EFG 113	EFG 115		
Two-stage ZT	h <sub>3</sub> mm	h <sub>2</sub> mm	h <sub>1</sub> mm	h <sub>4</sub> mm	α/β (°)	kg	kg	kg	kg	mm	mm
	2300	150	1650	2850	5/4	1000	1000	1250	1500	990	838
	3000 <sup>1)</sup>	150 <sup>1)</sup>	2000 <sup>1)</sup>	3550 <sup>1)</sup>	5/6 <sup>1)</sup>	1000	1000	1250	1500	990	838
	3100	150	2050	3650	5/6	1000	1000	1250	1500	990	838
	3300	150	2150	3850	5/6	1000	1000	1250	1500	990	838
	3600	150	2300	4150	5/6	1000	1000	1250	1500	990	838
	4000	150	2500	4550	5/6	1000	1000	1250	1500	990	838
Two-stage ZZ	4500	150	2800	5050	5/6	1000	1000	1250	1500	1062	910
	5000	150	3050	5550	5/5	1000	1000	1250	1400	1062	910
	2300	1055	1605	2850	5/4	1000	1000	1250	1500	990	838
	3000	1405	1955	3550	5/6	1000	1000	1250	1500	990	838
	3100	1455	2005	3650	5/6	1000	1000	1250	1500	990	838
	3300	1555	2105	3850	5/6	1000	1000	1250	1500	990	838
Three-stage DZ	3600	1705	2255	4150	5/6	1000	1000	1250	1500	990	838
	4000	1905	2455	4550	5/6	1000	1000	1250	1500	990	838
	4350	1405	1955	4900	5/6	1000	1000	1250	1500	990	838
	4500	1455	2005	5050	5/6	1000	1000	1250	1450	1062	910
	4800	1555	2105	5350	5/6	1000	1000	1250	1350	1062	910
	5000	1630	2180	5550	5/5	950	1000	1200	1300	1062	910
	5500	1805	2355	6050	5/5	850	900	1050	1200	1062	910
	6000	2005	2555	6550	5/4	-	800	850	1000	1062	910
6500	2255	2805	7050	5/4	-	-	700	900	1062	910	

1) standard

# Technical Data in line with VDI 2198 as at: 05/2007

Identification	1.1	Manufacturer (abbreviation)	Jungheinrich	Jungheinrich	Jungheinrich	Jungheinrich	1.1
	1.2	Manufacturer's type designation	<b>EFG 110k</b>	<b>EFG 110</b>	<b>EFG 113</b>	<b>EFG 115</b>	1.2
	1.3	Drive: electric (battery or mains), diesel, petrol, fuel gas, manual	electric	electric	electric	electric	1.3
	1.4	Type of operation: hand, pedestrian, standing, seated, order picker	seated	seated	seated	seated	1.4
	1.5	Load capacity/rated load Q (t)	1	1	1.25	1.5	1.5
	1.6	Load centre distance c (mm)	500	500	500	500	1.6
	1.8	Load distance, centre of drive axle to fork x (mm)	330 <sup>1)</sup>	330 <sup>1)</sup>	330 <sup>1)</sup>	330 <sup>1)</sup>	1.8
	1.9	Wheelbase y (mm)	984	1038	1146	1200	1.9
	Weights	2.1	Service weight incl. battery (see line 6.5) kg	2490	2570	2760	2870
2.2		Axle loading, laden front/rear kg	2940/550	2945/625	3390/620	3805/565	2.2
2.3		Axle loading, unladen front/rear kg	1095/1395	1145/1425	1235/1525	1270/1600	2.3
Wheels, Chassis	3.1	Tyres: solid rubber, superelastic, pneumatic, polyurethane	SE	SE	SE	SE	3.1
	3.2	Tyre size, front	18 x 7-8	18 x 7-8	18 x 7-8	18 x 7-8	3.2
	3.3	Tyre size, rear	18 x 7-8	18 x 7-8	18 x 7-8	18 x 7-8	3.3
	3.5	Wheels, number front rear (x = driven wheels)	2/1x	2/1x	2/1x	2/1x	3.5
	3.6	Track width, front b <sub>10</sub> (mm)	838	838	838	838	3.6
	3.7	Track width, rear b <sub>11</sub> (mm)	0	0	0	0	3.7
	Basic Dimensions	4.1	Mast/fork carriage tilt forward/backward $\alpha/\beta$ (°)	5/6	5/6	5/6	5/6
4.2		Lowered mast height h <sub>1</sub> (mm)	2000	2000	2000	2000	4.2
4.3		Free lift h <sub>2</sub> (mm)	150	150	150	150	4.3
4.4		Lift height h <sub>3</sub> (mm)	3000	3000	3000	3000	4.4
4.5		Extended mast height h <sub>4</sub> (mm)	3550	3550	3550	3550	4.5
4.7		Overhead load guard (cab) height h <sub>6</sub> (mm)	2090	2090	2090	2090	4.7
4.8		Seat height/standing height h <sub>7</sub> (mm)	900	900	900	900	4.8
4.12		Coupling height h <sub>10</sub> (mm)	635	635	635	635	4.12
4.19		Overall length l <sub>1</sub> (mm)	2719	2773	2881	2935	4.19
4.20		Length to face of forks l <sub>2</sub> (mm)	1569	1623	1731	1785	4.20
4.21		Overall width b <sub>1</sub> /b <sub>2</sub> (mm)	990/-	990/-	990/-	990/-	4.21
4.22		Fork dimensions s/e/l (mm)	35x100x1150	35x100x1150	35x100x1150	35x100x1150	4.22
4.23		Fork carriage ISO 2328, class/type A, B	ISO 2A	ISO 2A	ISO 2A	ISO 2A	4.23
4.24		Fork-carriage width b <sub>3</sub> (mm)	950	950	950	950	4.24
4.31		Ground clearance, laden, under mast m <sub>1</sub> (mm)	90	90	90	90	4.31
4.32		Ground clearance, centre of wheelbase m <sub>2</sub> (mm)	100	100	100	100	4.32
4.33	Aisle width for pallets 1000x1200 crossways Ast (mm)	2898	2952	3060	3114	4.33	
4.34	Aisle width for pallets 800x1200 lengthways Ast (mm)	3020	3074	3182	3236	4.34	
4.35	Turning radius Wa (mm)	1239	1293	1401	1455	4.35	
4.36	Smallest pivot point distance b <sub>13</sub> (mm)	0	0	0	0	4.36	
Performance Data	5.1	Travel speed, laden/unladen km/h	12/12.5	12/12.5	12/12.5	12/12.5	5.1
	5.2	Lift speed, laden/unladen m/s	0.28/0.50	0.29/0.50	0.25/0.50	0.24/0.50	5.2
	5.3	Lowering speed, laden/unladen m/s	0.58/0.60	0.58/0.60	0.58/0.60	0.58/0.60	5.3
	5.5	Drawbar pull, laden/unladen S <sub>2</sub> 60 min N	1150/1250	1150/1250	1100/1250	1055/1250	5.5
	5.6	Max. drawbar pull, laden/unladen S <sub>2</sub> 5 min N	4400/4500	4400/4500	4375/4500	4350/4500	5.6
	5.7	Gradient performance, laden/unladen S <sub>2</sub> 30 min %	8.5/12	8/11,5	7/11	6.5/10.5	5.7
	5.8	Max. gradient performance, laden/unladen S <sub>2</sub> 5 min %	13/18	12.5/17.5	11/16.5	10/16	5.8
	5.9	Acceleration time, laden/unladen 10 m s	5.1/4.6	5.1/4.6	5.4/4.7	5.6/4.8	5.9
	5.10	Service brake	hydr.	hydr.	hydr.	hydr.	5.10
	E-Motor	6.1	Drive motor rating S <sub>2</sub> 60 min kW	4.0	4.0	4.0	4.0
6.2		Lift motor rating at S <sub>2</sub> 20 % kW	6	6	6	6	6.2
6.3		Battery acc. to DIN 43531/35/36 A, B, C, no	43535 A	43535 A	43535 A	43535 A	6.3
6.4		Battery voltage, nominal capacity K <sub>s</sub> V/Ah	24/460	24/575	24/805	24/920	6.4
6.5		Battery weight kg	380	450	600	690	6.5
6.6		Battery dimensions l/w/h mm	830/273/627	830/327/627	830/435/627	830/489/627	6.6
Other Details	8.1	Energy consumption acc. to VDI cycle <sup>2)</sup> kWh/h	3.6	3.6	3.9	4.1	6.6
	8.1	Type of drive control	Impulse/AC	Impulse/AC	Impulse/AC	Impulse/AC	8.1
	8.2	Operating pressure for attachments bar	160	160	185	210	8.2
	8.3	Oil volume for attachments l/min	14	14	14	14	8.3
	8.4	Sound level at driver's ear according to DIN 12053 dB(A)	63	63	63	63	8.4
8.5	Tow coupling, type DIN	DIN 15170-H	DIN 15170-H	DIN 15170-H	DIN 15170-H	8.5	

1) 337 mm with DZ mast, with integrated sideshift: x = 362 mm (369 mm with DZ mast), with sideshift attachment: x = 390 mm (397 mm with DZ mast)

2) 45 VDI working cycles/h

# Make use of the advantages

## High productivity

First class driver productivity through comfortable operator's compartment, high performance and low life cycle costs.

## High residual carrying capacity

Full rated capacity up to 4500 mm on the EFG 115 on the EFG 110 k/110/113 a lift height of 5000 mm can be achieved. This is due to excellent stability safety.

## Innovative motor technology

Drive and lift motor with AC technology and excellent heat economics (no ventilator required).



Drive and lift motor with AC technology

## Performance enhancing workstation

- Standard comfort high roof for superior headroom.
- Clear view: mast and fork carriage allow for excellent visibility.
- Comfortable operation of direction and hydraulics by SOLO-PILOT or MULTI-PILOT (optional).
- Low effort hydraulic power steering (5,2 turns for 180° angle of lock).

## Highly reduced maintenance

- Single-piece metal cover ensures quick and easy access to the battery compartment.



SOLO-PILOT

- Maintenance and wear-free motors in AC technology.
- Dirt, dampness and water-resistant motors due to encapsulated design and electronic components complying to IP 54.
- Prolonged service intervals: only every 1000 operating hours or every 6 months.
- Hydraulic steering with fully encapsulated cog-wheel system.

## Economic driving and lifting

- AC technology ensures optimum performance.
- Energy regeneration system.
- Omission of motor ventilators.
- Significantly prolonged work cycles, increasing charging intervals.
- Progressive lowering brake valve allows equal lowering speed with and without load.

## Innovative steering and safety technology

- Impulse ac technology steering allows sensitive driving.
- Programmable performance parameter ensure flexibility.
- 5 selectable drive programs (optional)
- Jungheinrich Curve Control reduces speed depending on the steering angle (optional).

## SOLO-PILOT

The SOLO-PILOT (standard equipment) combines the functions lifting/lowering, direction switch and horn in one control lever. The additional functions forward/backward tilting, sideshift (optional) and supplementary hydraulic (optional) can be operated with addition levers situated directly next to the SOLO-PILOT.

## MULTI-PILOT

The MULTI-PILOT (optional) combines all drive and hydraulic functions in one central control lever. Without having to move the hand all control commands can easily be received. The hand rests on the ergonomically positioned handle. Even controlling several hydraulic functions is done in no time with the MULTI-PILOT.



MULTI-PILOT

## AC technology motors

Fully closed AC technology motors – brushless – are the main component of the maintenance free drive unit. They are resistant to dust, dirt and dampness. The temperature control protects the motors from overheating by adjusting the performance.

## Jungheinrich Hellas EPE

10, Filippoupoleos str.  
Thesi Loutro  
136 71 Acharnes  
Greece  
Tel. 0030 210 2447800  
Fax 0030 210 2447799

info@jungheinrich.gr  
www.jungheinrich.gr

Jungheinrich AG  
ISO 9001, ISO 14001  
Certification of Quality and  
Environment Management.



Jungheinrich trucks  
conform to the European  
Safety Requirements.



**JUNGHEINRICH**  
Η επιλογή που αξίζει