

**High performance electric forklift with enclosed, twin AC motor front wheel drive**

**5 individually adjustable working programs**

**Comfortable workstation with SOLO- or MULTI-PILOT control (optional)**

**Jungheinrich Curve Control for safer driving and cornering**

**Maintenance-free multiple disc brakes**



## EFG 213–220

### Electric three-wheel forklift truck (1300, 1500, 1600, 1800, 2000 kg)

The use of innovative three-phase AC technology opens up new possibilities and provides numerous advantages for electric forklift trucks:

- Excellent performance values for acceleration, travel and lift speeds allow for maximum productivity.
- More work per battery charge as a result of optimum efficiency and more effective energy recovery.
- Precise hydrostatic power steering and solid-state electric braking when the accelerator is released.

- Maintenance-free brushless enclosed three phase AC motors protected to IP 54.

This ensures faster working cycles and significantly longer operation per battery charge. Low day-to-day operating costs, together with reduced maintenance requirements, guarantee outstanding economic efficiency.

Compact design makes the three wheel truck extremely manoeuvrable and allows fast operation in the most confined spaces

for example lorries, containers or railway wagons. The closed design and the front wheel drive ensure a universal suitability and optimal traction on gradients and slippery surfaces.

# EFG 213–220

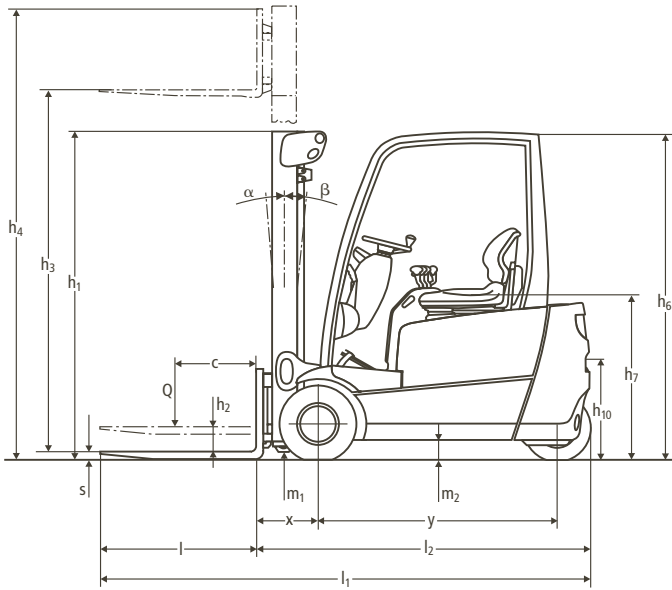

## Capacity

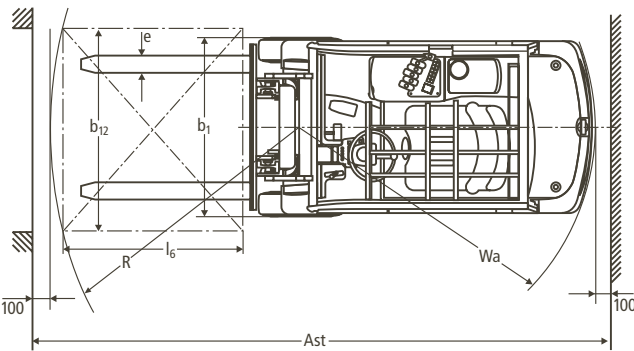
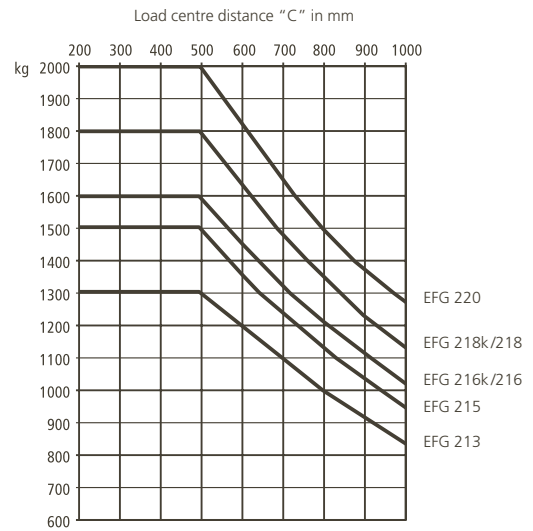

Designation	Mast table EFG 213–220						Forward/ backward tilt $\alpha/\beta$ (°)	Capacity table (kg) c = 500 mm				
	Lift height $h_3$ mm	Free lift $h_2$ mm		Closed mast height $h_1$ mm	Extended mast height $h_4$ mm			without sideshift, single solid tyres				
		EFG 213–216	EFG 218–220		EFG 213–216	EFG 218–220		EFG 213	EFG 215	EFG 216k/216	EFG 218k/218	EFG 220
Two-stage ZT	2300	150	150	1650	2860	2887	7/4	1300	1500	1600	1800	2000
	3000	150	150	2000	3560	3587	7/7	1300	1500	1600	1800	2000
	3100	150	150	2050	3660	3687	7/7	1300	1500	1600	1800	2000
	3300	150	150	2150	3860	3887	7/7	1300	1500	1600	1800	2000
	3600	150	150	2300	4160	4187	7/7	1300	1500	1600	1800	2000
	4000	150	150	2500	4560	4587	7/7	1300	1500	1600	1800	2000
	4500	150	150	2800	5060	5087	7/7	1300	1500	1600	1800	2000
	5000	150	150	3050	5560	5587	7/5	1200	1400	1500	1700	1850
5500*	150	150	3400	6060	6087	7/5	1100	–	1400	1550	1650	
Two-stage ZZ	2300	1045	988	1605	2860	2917	7/4	1300	1500	1600	1800	2000
	3000	1395	1338	1955	3560	3617	7/7	1300	1500	1600	1800	2000
	3100	1445	1388	2005	3660	3717	7/7	1300	1500	1600	1800	2000
	3300	1545	1488	2105	3860	3917	7/7	1300	1500	1600	1800	2000
	3600	1695	1638	2255	4160	4217	7/7	1300	1500	1600	1800	2000
	4000	1895	1838	2455	4560	4617	7/7	1300	1500	1600	1800	2000
Three-stage DZ	4350	1395	1338	1955	4910	4967	7/7	1300	1500	1600	1800	2000
	4500	1445	1388	2005	5060	5117	7/7	1300	1450	1600	1800	2000
	4800	1545	1488	2105	5360	5417	7/6	1250	1400	1550	1700	1900
	5000	1620	1563	2180	5560	5617	7/6	1200	1350	1500	1650	1800
	5500	1795	1738	2355	6060	6117	7/5	1050	1250	1350	1500	1600
	6000*	1995	1938	2555	6560	6617	7/5	900	–	1150	1300	1400
	6500*	2245	2188	2805	7060	7117	7/5	750	–	950	1100	1150

\* Mast not available for EFG 215

# Technical Data in line with VDI 2198 as at: 05/2007

Identification	1.1	Manufacturer (abbreviation)	Jungheinrich		Jungheinrich		Jungheinrich		Jungheinrich	1.1	
	1.2	Manufacturer's type designation	EFG 213	EFG 215	EFG 216k	EFG 216	EFG 218k	EFG 218	EFG 220	1.2	
	1.3	Drive: electric (battery or mains), diesel, petrol, fuel gas, manual	electric		electric		electric		electric	1.3	
	1.4	Type of operation: hand, pedestrian, standing, seated, order picker	seated		seated		seated		seated	1.4	
	1.5	Load capacity/rated load	Q (t)	1.3	1.5	1.6		1.8		2.0	1.5
	1.6	Load centre distance	c (mm)	500		500		500		500	1.6
	1.8	Load distance, centre of drive axle to fork	x (mm)	347 <sup>1)</sup>		352 <sup>2)</sup>		352 <sup>2)</sup>		352 <sup>2)</sup>	1.8
	1.9	Wheelbase	y (mm)	1249		1357	1465	1357	1465	1465	1.9
	Weights	2.1	Service weight incl. battery (see line 6.5)	kg	2800	2990	2990	3185	3100	3170	3205
2.2		Axle loading, laden front/rear	kg	3490/610	3930/560	4015/575	4030/755	4415/485	4375/595	4665/540	2.2
2.3		Axle loading, unladen front/rear	kg	1310/1490	1415/1575	1410/1580	1500/1685	1485/1615	1530/1640	1500/1705	2.3
Wheels, Chassis	3.1	Tyres: solid rubber, superelastic, pneumatic, polyurethane	SE(L)/SE(L)		SE(L)/SE(L)		SE/SE		SE/SE	3.1	
	3.2	Tyre size, front	18x7-8		18x7-8		200/50-10		200/50-10	3.2	
	3.3	Tyre size, rear	140/55-9		140/55-9		140/55-9		140/55-9	3.3	
	3.5	Wheels, number front rear (x = driven wheels)	2x/2		2x/2		2x/2		2x/2	3.5	
	3.6	Track width, front	b <sub>10</sub> (mm)	904		904		914		914	3.6
	3.7	Track width, rear	b <sub>11</sub> (mm)	176		176		176		176	3.7
	Basic Dimensions	4.1	Mast/fork carriage tilt forward/backward	α/β (°)	7/7		7/7		7/7		7/7
4.2		Lowered mast height	h <sub>1</sub> (mm)	2000		2000		2000		2000	4.2
4.3		Free lift	h <sub>2</sub> (mm)	150		150		150		150	4.3
4.4		Lift height	h <sub>3</sub> (mm)	3000		3000		3000		3000	4.4
4.5		Extended mast height	h <sub>4</sub> (mm)	3560		3560		3587		3587	4.5
4.7		Overhead load guard (cab) height	h <sub>6</sub> (mm)	1960		1960		1960		1960	4.7
4.8		Seat height/standing height	h <sub>7</sub> (mm)	890		890		890		890	4.8
4.12		Coupling height	h <sub>10</sub> (mm)	560		560		560		560	4.12
4.19		Overall length	l <sub>1</sub> (mm)	2936		3049	3157	3049	3157	3157	4.19
4.20		Length to face of forks	l <sub>2</sub> (mm)	1786		1899	2007	1899	2007	2007	4.20
4.21		Overall width	b <sub>1</sub> /b <sub>2</sub> (mm)	1060/-		1060/-		1120/-		1120/-	4.21
4.22		Fork dimensions	s/e/l (mm)	35x100x1150		40x100x1150		40x100x1150		40x100x1150	4.22
4.23		Fork carriage ISO 2328, class/type A, B		2A		2A		2A		2A	4.23
4.24		Fork-carriage width	b <sub>3</sub> (mm)	980		980		980		980	4.24
4.31		Ground clearance, laden, under mast	m <sub>1</sub> (mm)	90		90		90		90	4.31
4.32		Ground clearance, centre of wheelbase	m <sub>2</sub> (mm)	100		100		100		100	4.32
4.33	Aisle width for pallets 1000x1200 crossways	Ast (mm)	3115		3224	3334	3224	3334	3334	4.33	
4.34	Aisle width for pallets 800x1200 lengthways	Ast (mm)	3238		3348	3458	3348	3458	3458	4.34	
4.35	Turning radius	Wa (mm)	1440		1545	1655	1545	1655	1655	4.35	
4.36	Smallest pivot point distance	b <sub>13</sub> (mm)	0		0		0		0	4.36	
Performance Data	5.1	Travel speed, laden/unladen	km/h	16.0		16.0		16.0		16.0	5.1
	5.2	Lift speed, laden/unladen	m/s	0.48/0.60	0.46/0.60	0.46/0.60		0.38/0.50		0.38/0.50	5.2
	5.3	Lowering speed, laden/unladen	m/s	0.55		0.55		0.55		0.55	5.3
	5.5	Drawbar pull, laden/unladen S <sub>2</sub> 60 min	N	2300/2500	2200/2450	2150/2450	2100/2450	2000/2300		1900/2300	5.5
	5.6	Max. drawbar pull, laden/unladen S <sub>2</sub> 5 min	N	12700/12700		12700/12700		12400/12200		12300/12000	5.6
	5.7	Gradient performance, laden/unladen S <sub>2</sub> 30 min	%	7.6/12.5	7.3/12.3	7.3/12.3	7.0/11.5	6.2/10.7	5.9/10.5	5.7/10.4	5.7
	5.8	Max. gradient performance, laden/unladen S <sub>2</sub> 5 min	%	28.0/35.0	27.0/35.0	27.0/35.0		26.0/35.0	25.0/35.0	24.0/35.0	5.8
	5.9	Acceleration time, laden/unladen 10 m	s	3.6/3.2	3.8/3.4	3.8/3.4		3.9/3.5		4.0/3.5	5.9
	5.10	Service brake		hydr./electr.		hydr./electr.		hydr./electr.		hydr./electr.	5.10
	E-Motor	6.1	Drive motor rating S <sub>2</sub> 60 min	kW	4.0/4.0		4.0/4.0		4.0/4.0		4.0/4.0
6.2		Lift motor rating at S <sub>3</sub> 15 %	kW	10.0		10.0		10.0		10.0	6.2
6.3		Battery acc. to DIN 43531/35/36 A, B, C, no		DIN 43531 A		DIN 43531 A	DIN 43531 A	DIN 43531 A	DIN 43531 A	DIN 43531 A	6.3
6.4		Battery voltage, nominal capacity K <sub>s</sub>	V/Ah	48/460		48/575	48/690	48/575	48/690	48/690	6.4
6.5		Battery weight	kg	715		855	1025	855	1025	1025	6.5
6.6		Battery dimensions l/w/h	mm	830/522/627		830/630/627	830/738/627	830/630/627	830/738/627	830/738/627	6.6
Other Details	8.1	Energy consumption acc. to VDI cycle <sup>3)</sup>	kWh/h	3.9	4.1	4.1		4.3		4.5	6.6
	8.1	Type of drive control		Impulse/AC		Impulse/AC		Impulse/AC		Impulse/AC	8.1
	8.2	Operating pressure for attachments	bar	approx. 200		approx. 200		approx. 200		approx. 200	8.2
	8.3	Oil volume for attachments	l/min	25		25		25		25	8.3
	8.4	Sound level at driver's ear according to DIN 12053 dB(A)		66		66		66		66	8.4
8.5	Tow coupling, type DIN		15170/type H		15170/type H		15170/type H		15170/type H	8.5	

1) 372 mm with DZ mast, with integrated sidishift: x = 370 mm (395 mm with DZ mast), with sidishift attachment: x = 405.5 mm (425.5 mm with DZ mast)

2) 377 mm with DZ mast, with integrated sidishift: x = 375 mm (400 mm with DZ mast), with sidishift attachment: x = 410.5 mm (435.5 mm with DZ mast)

3) 45 VDI working cycles/h

# Make use of the advantages

## Superior operator comfort

Functionality and ergonomics of the driver compartment guarantees relaxed and fatigue-free work over long shifts:

- Low access step. Large, level foot well with automotive pedal lay-out.
- Adjustable steering column and hydraulic comfort seat for optimum seating position.
- Floating cab module cushions road shocks and vibrations.
- Clear view: mast and fork carriage allow for excellent visibility to load and road.
- Hydraulic power steering is precise and low effort, without kick-back.



SOLO-PILOT

- Comfort Display provides up-to-date information on vital vehicle conditions at a glance.
- Comfortable, fatigue-free operation of direction and hydraulics by SOLO-PILOT control (separate levers) or MULTI-PILOT control (optional), all functions controlled by one lever.
- Convenient storage for documents and the operators belongings.

## Safe, wear-free braking

Three distinct systems ensure safe, precise and largely wear-free braking:

- Regenerative electric braking in reversing mode and regular brake pedal use.



MULTI-PILOT

- Multiple oil disc brakes act as a safety back-up. Wear-free and fully enclosed.
- Parking brake uses the service brake system through a separate electric actuation system. Operation warning light in the drivers console.

## Maintenance free electric motors

Proven AC technology: 2 drive motors, hydraulic pump motor, steering motor. High performance, low energy consumption, less maintenance:

- High torque for rapid work cycles.
- Up to 15% higher energy efficiency than shunt motors.
- No brushes, no collector – no maintenance expense.
- Fully enclosed and protected to IP 54. Long life, even under dusty and damp conditions.
- 2 years warranty on all motors.

## Active safety

Excellent drive dynamics and performance also demand a high degree of safety:

- Curve Control automatically reduces travel speed when cornering.
- Rollback protection ensures controlled operation on ramps and slopes.
- Very low centre of gravity improves stability and residual capacity.

- Twin wheel steering axle with low profile tyres ensures stable handling and smooth travel.
- Electronic and hydraulic overload protection guard.
- Traction Control ensures optimum torque in curves.
- Emergency cut off switch quickly accessible.
- Reliable data transfer between electronic components through CAN-Bus technology.

## Intelligent electronics

BoardControl electronic system permanently controls and monitors all truck functions.

- Smooth driving, dynamic reversing and precise load positioning with a minimum of energy.



Comfort Display

- 5 application programs can be individually adapted to ensure optimal performance in any application.
- Diagnostic system monitors all components and provides service data memory for rapid and cost-effective maintenance.
- Comfort Display with digital service hour meter (actual or cyclic duration factor), battery discharge indicator plus lift cut-out, clock, error code and warning displays.
- Electronic steer wheel position indicator.

## Jungheinrich Hellas EPE

10, Filippoupoleos str.  
Thesi Loutro  
136 71 Acharnes  
Greece  
Tel. 0030 210 2447800  
Fax 0030 210 2447799

info@jungheinrich.gr  
www.jungheinrich.gr

Jungheinrich AG  
ISO 9001, ISO 14001  
Certification of Quality and  
Environment Management.



Jungheinrich trucks  
conform to the European  
Safety Requirements.



**JUNGHEINRICH**  
Η επιλογή που αξίζει