

**Robust and powerful
for the hardest applications
with heavy loads**

**Excellent stability on cornering
with ProTracLink**

**Easy operation with the tiller
in the upright position by
using the crawl speed button**

**Multi-shift operation with
sideways battery exit (optional)**



EJE 220/225

Electric pedestrian controlled pallet truck (2000/2500 kg)

The EJE 2 Series pallet trucks are extremely powerful. They are used where high productivity is needed e.g. during lorry loading and offloading on the ramp, in hard continuous operation with heavy loads, during 2-shift or even 3-shift operations. The advantages of the EJE are particularly effective here:

- Powerful, innovative 1.6 kW 3-phase AC drive motor for high productivity.
- High load capacities and powerful lift motor.
- Robust chassis and load section (EJE 225) for heavy duty operation.

- Most up-to-date control electronics for easy operation.
- Excellent energy management for low operating costs.
- Large batteries for long application times.

There are also ergonomic advantages: the long tiller handle keeps the operator at a safe distance from the truck chassis. The crawl speed button assists in very confined spaces and allows operators with the tiller in the upright position to operate the truck at a reduced speed. The EJE can be equipped with batteries up to 375 Ah. In combination with state of the art and

economical 3-phase AC technology, longer operating times are achieved than with a traditional power supply. The optionally available sideways battery removal allows multi-shift operation.

The completely redeveloped multifunction tiller head is full of innovations: enclosed sensor system (IP 65) for protection against breakdown, rocker switch with contactless electronics for smooth operation in every tiller position and ergonomically arranged switches.

EJE 220/225

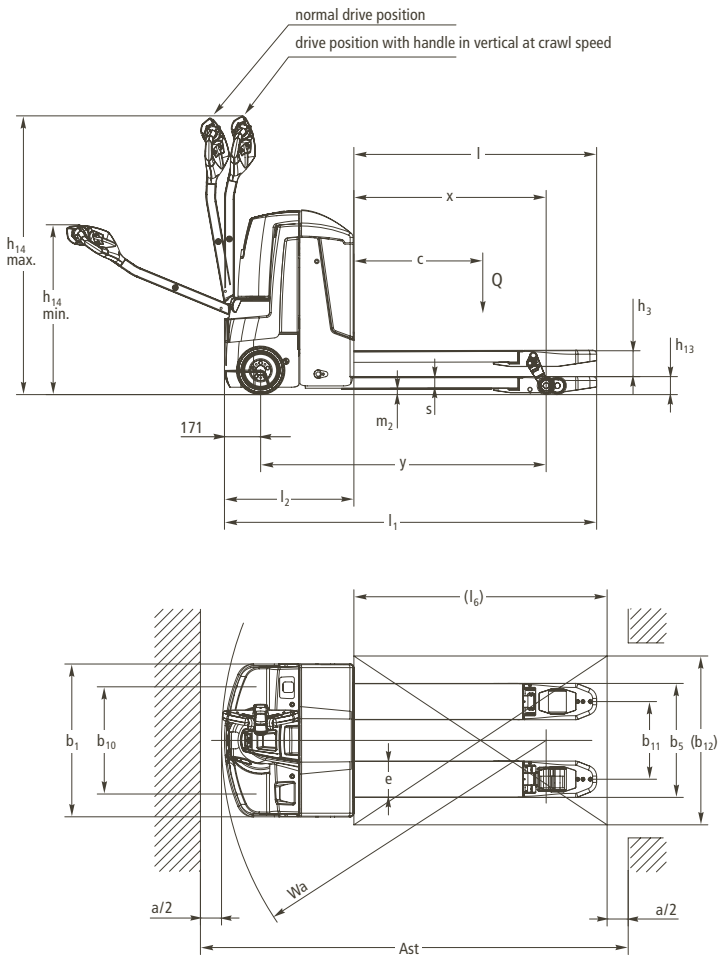

Technical data in line with VDI 2198 as at: 06/2007

Identification	1.1	Manufacturer (abbreviation)		Jungheinrich	Jungheinrich	1.1
	1.2	Manufacturer's type designation		EJE 220	EJE 225	1.2
	1.3	Drive		electric	electric	1.3
	1.4	Operator type		pedestrian	pedestrian	1.4
	1.5	Load capacity/rated load	Q (t)	2,0	2,5	1.5
	1.6	Load centre distance	c (mm)	600	600	1.6
	1.8	Load distance, centre of drive axle to fork	x (mm)	911 ¹⁾	911 ¹⁾	1.8
	1.9	Wheelbase	y (mm)	1353 ¹⁾	1353/1425 ¹⁾	1.9
	Weights	2.1	Service weight incl. battery (see line 6.5)	kg	540	647
2.2		Axle loading, laden front/rear	kg	876/1664	1034/2113	2.2
2.3		Axle loading, unladen front/rear	kg	423/117	497/150	2.3
Wheels, Chassis	3.1	Tyres		PU/Vulkollan®	PU/Vulkollan®	3.1
	3.2	Tyre size, front		230x70	230x70	3.2
	3.3	Tyre size, rear		85x110	85x110	3.3
	3.4	Additional wheels (dimensions)		100x40	100x40	3.4
	3.5	Wheels, number front rear (x = driven wheels)		1x + 2	1x + 2	3.5
	3.6	Tread, front	b ₁₀ (mm)	508	508	3.6
	3.7	Tread, rear	b ₁₁ (mm)	368	368	3.7
Basic Dimensions	4.4	Normal lift height	h ₃ (mm)	122	122	4.4
	4.9	Height of tiller in drive position min./max.	h ₁₄ (mm)	805/1321	805/1321	4.9
	4.15	Height, lowered	h ₁₃ (mm)	85	85	4.15
	4.19	Overall length	l ₁ (mm)	1763/1835	1763/1835	4.19
	4.20	Length to face of forks	l ₂ (mm)	613/685	613/685	4.20
	4.21	Overall width	b ₁ (mm)	720	720	4.21
	4.22	Fork dimensions	s/e/l (mm)	55 x 172 x 1150	55 x 172 x 1150	4.22
	4.25	Distance between fork-arms	b ₅ (mm)	540	540	4.25
	4.32	Ground clearance, centre of wheelbase	m ₂ (mm)	30	30	4.32
	4.33	Aisle width for pallets 1000 x 1200 crossways	Ast (mm)	1977/2049 ²⁾	1977/2049 ²⁾	4.33
	4.34	Aisle width for pallets 800 x 1200 lengthways	Ast (mm)	2027/2099 ³⁾	2027/2099 ³⁾	4.34
4.35	Turning radius	Wa (mm)	1538/1610 ¹⁾	1538/1610 ¹⁾	4.35	
Performance Data	5.1	Travel speed, laden/unladen	km/h	6,0/6,0	6,0/6,0	5.1
	5.2	Lift speed, laden/unladen	m/s	0,04/0,06	0,03/0,06	5.2
	5.3	Lowering speed, laden/unladen	m/s	0,05/0,05	0,05/0,05	5.3
	5.8	Max. gradeability, laden/unladen	%	10/20	8/20	5.8
	5.10	Service brake		electric	electric	5.10
Electric engine	6.1	Drive motor rating S ₂ 60 min.	kW	1,6	1,6	6.1
	6.2	Lift motor rating at S ₃ 10 %	kW	1,5	1,5	6.2
	6.3	Battery acc. to DIN 43531 / 35/36 A, B, C, no		DIN B	DIN B	6.3
	6.4	Battery voltage, nominal capacity K _s	V/Ah	24/250	24/250 24/375	6.4
	6.5	Battery weight	kg	220	288	6.5
Others	8.1	Type of drive control		AC SpeedControl	AC SpeedControl	8.1
	8.4	Sound level at the driver's ear according to DIN 12 053	dB(A)	70	70	8.4

- 1) load section lowered: + 55 mm
2) diagonal according to VDI: + 366 mm
3) diagonal according to VDI: + 204 mm

Make use of the advantages

Innovative 3-phase AC technology

Jungheinrich motors in 3-phase AC technology provide increased efficiency with reduced operating costs at the same time:

- Highly efficient with excellent energy management.
- Powerful acceleration even with maximum load.
- Quick direction change without the usual time delay.
- No carbon brushes – the drive motor is maintenance-free.
- 2-year warranty on drive motor.



Collision protection on EJE 225 battery compartment

Robust construction for hardest applications

- Drive unit apron made of high quality 8 mm steel.
- Additional collision protection on battery compartment to guard the battery container against damage from the load.

- Reinforced fork section for high capacities.

Optimum cornering

Sprung and cushioned support wheels linked via the torsion bar suspension "ProTracLink" – distribute equalising forces dependent on travel conditions i.e. evenly over all wheels during straight travel; concentrated on the outer support wheel during cornering. "ProTracLink" also ensures low support wheel damage during ramp work due to its self levelling adjustment. A torsion bar constantly keeps both support wheels at the same height reducing the chance of catching or damage to the lower support wheel.

Ergonomic operation

The redeveloped tiller head is perfectly adjusted to operator requirements:

- Clear colour system and keys with sunken/raised sections allowing intuitive operation.
- Handle position adjusted to suit natural operation.
- Crawl speed button on the underside of the tiller head for quick access and easy operation with the tiller in the vertical position.



Ergonomic tiller head



The EJE in hard everyday application

- Rocker switch for smooth operation in any tiller position.
- The tiller head also has excellent protection against breakdown with a contactless sensor system which has IP 65 protection against water ingress.

Long operating times

Battery capacities up to 375 Ah ensure long operating times:

- Short version: 2 EPzS 180/250 Ah.
- Long version: 2 EPzS 375 Ah (only EJE 225).
- Integrated charger (24V/30A for wet batteries and maintenance-free batteries) for effortless charging at any mains socket (optional).
- Sideways battery exit for multi-shift operation (optional).

Additional equipment

- Cold store design.
- Entry rollers.
- Vertical load guard.

Jungheinrich Hellas EPE

10, Filippoupoleos str.
Thesi Loutro
136 71 Acharnes
Greece
Tel. 0030 210 2447800
Fax 0030 210 2447799

info@jungheinrich.gr
www.jungheinrich.gr

Jungheinrich AG
ISO 9001, ISO 14001
Certification of Quality and
Environment Management.



Jungheinrich trucks
conform to the European
Safety Requirements.



JUNGHEINRICH
Η επιλογή που αξίζει